

Royal Society of Chemistry
Five-Decade Exam Challenge

Candidate Name:	School:
------------------------	----------------

Start-time: <i>12.00 pm</i>	End-time:
------------------------------------	------------------

I certify that the candidate above has carried out this examination under supervision, and by the rules expressed by the Royal Society of Chemistry.

I confirm the above end-time for the exam completion is correct.

Supervisor Name:	Signature:
-------------------------	-------------------

Instruction leaflet – Please read carefully
Only this page may be handed to candidates before the exam starts

Rules

Candidates **must not** be handed the booklet until they have logged onto and started the first question of the online version of the exam, which they must do at 12 noon.

The only window which should be open on the computer is that for the exam. It is **Strictly Forbidden** for students to use the internet to search for answers for questions.

Instructions for Candidates

Candidates **must** attempt all 10 questions in Section A to be eligible to win.

Section B is the bonus section and candidates should attempt as many questions in this section as possible. In order to win and gain the highest marks, it is expected that all 30 questions in section B will need to be attempted.

In the case of a tie for top marks, the examination completed in the shortest time will win.

Candidates are allowed to use a calculator.

Please show any working you do on this paper, along with your answers, which must also be typed into the online version of the exam. If more space is needed, please work on separate paper, which should be named and attached to this document on completion.

Numerical Answers

If a numerical answer is needed, the units required will be given in the question.

DO NOT TYPE THE UNITS IN THE ANSWER BOXES

For numerical answers the **number of significant figures** you should give will be indicated in the question (e.g. if *3 sig. figs* is asked for these formats should be written 0.0200, 121000, 36.1)

Powers of 10

Answers which you wish to multiply by a power of 10 (e.g. 6.5×10^5) should be written in the format **6.5E5** for the online version. (i.e replace 'x10' with the letter 'E' followed by the exponent). Alternatively they can be typed out in full. E.g. **0.000065**.

H 1 1.00	He 2 4.003
Li 3 7	Be 4 9.01
Na 11 23	Mg 12 24
K 19 39.102	Ca 20 40.0
Rb 37 85.47	Sr 38 87.62
Cs 55 132.91	Ba 56 137
Fr 87	Ra 88
	Sc 21 44.96
	Y 39 88.91
	La* 57 138.91
	Ac* 89
	Ti 22 47.90
	Zr 40 91.22
	Hf 72 178.49
	V 23 50.94
	Nb 41 92.91
	Ta 73 180.95
	Cr 24 52.00
	Mo 42 95.94
	W 74 183.85
	Mn 25 54.94
	Tc 43
	Re 75 186.2
	Fe 26 56
	Ru 44 101.07
	Os 76 190.2
	Co 27 58.93
	Rh 45 102.91
	Ir 77 192.2
	Ni 28 58.71
	Pd 46 106.4
	Pt 78 195.09
	Cu 29 64
	Ag 47 107.87
	Au 79 196.97
	Zn 30 65
	Cd 48 112.40
	Hg 80 200.59
	Ga 31 69.72
	In 49 114.82
	Tl 81 204.37
	Ge 32 72.59
	Sn 50 118.69
	Pb 82 207
	As 33 74.92
	Sb 51 121.75
	Bi 83 208.98
	Se 34 78.96
	Te 52 127.60
	Po 84
	Br 35 79.904
	I 53 126.90
	At 85
	S 16 32.0
	Se 34 78.96
	Te 52 127.60
	Po 84
	Cl 17 35.45
	Ar 18 39.95
	Kr 36 83.80
	Xe 54 131.30
	Rn 86

symbol
atomic number
mean atomic mass

*Lanthanides	Ce 58 140.12	Pr 59 140.91	Nd 60 144.24	Pm 61	Sm 62 150.4	Eu 63 151.96	Gd 64 157.25	Tb 65 158.93	Dy 66 162.50	Ho 67 164.93	Er 68 167.26	Tm 69 168.93	Yb 70 173.04	Lu 71 174.97
+Actinides	Th 90 232.01	Pa 91	U 92 238.03	Np 93	Pu 94	Am 95	Cm 96	Bk 97	Cf 98	Es 99	Fm 100	Md 101	No 102	Lr 103

Section A - Compulsory Section

A2.

The solubility of sodium nitrate in water, at various temperatures, is given in the table.

Temperature (°C)	0	10	20	30	40	50	60
Solubility (g/100 g water)	72	78	84	95	104	112	124

- (i) A saturated solution of sodium nitrate containing 25 g of water is cooled from 50 °C to 20 °C. Calculate the mass of sodium nitrate which would crystallise. (**Answer in grams to 1 sig. fig.**)

A mixture **X** containing 10 g of water and 10 g of sodium nitrate at 30 °C is prepared. After stirring, some of the solid is seen to remain at the bottom of the flask.

- (ii) What is the maximum mass of sodium nitrate which would dissolve in 10 g of water at 30 °C? (**Answer in grams to 2 sig. fig.**)

A3.

Calculate the percentage by mass of phosphorus present in calcium phosphate, $\text{Ca}_3(\text{PO}_4)_2$. Relative atomic masses: Ca = 40; P = 31; O = 16. (**Answer in % to 3 sig. fig.**)

Section A - Compulsory Section

A4.

The amount of energy released by the combustion of carbon is $-394,000 \text{ J mol}^{-1}$.

- (a) Calculate the mass of coal which must be burned in a coal-burning power station in order to liberate 10^9 J of energy (which is the amount liberated on the fission of 10 milligrams of ^{235}U). Assume that coal is pure carbon. (Relative atomic mass: C = 12) **(Answer in kg to 3 sig. fig.)**

- (b) Calculate the mass of carbon dioxide that would be released into the atmosphere during the combustion in (a) above. (Relative atomic masses: C = 12; O = 16) **(Answer in kg to 3 sig. fig.)**

- (c) State one environmental advantage and one environmental disadvantage of nuclear power stations against coal-burning power stations. **(in fewer than 8 words for each)**

Advantage:

Disadvantage:

Section A - Compulsory Section

A5.

Equal volumes of the vapour of an alcohol **X** and of oxygen gas have the same mass at the same temperature and pressure. Oxidation of **X** gives a weak acid **Y** of molecular formula H_2CO_2 . 2.3g of **Y** neutralise 50 cm^3 of 1.0M sodium hydroxide. (Relative atomic masses: C = 12; H = 1; O = 16)

(a) What is the relative molecular mass of **X**?

(b) What is the relative molecular mass of the acid **Y**?

(c) What volume of 1.0M sodium hydroxide would be needed to neutralise one mole of **Y**? (**Answer in dm^3 to 2 sig. fig.**)

A6.

Nitrogen can be obtained by heating solid ammonium dichromate(VI), $(\text{NH}_4)_2\text{Cr}_2\text{O}_7$.

Chromium (III) oxide (Cr_2O_3) and steam are the only other products of this reaction.

(i) ONLY ON THIS ANSWER SHEET (not on the online exam) construct the equation, including state symbols, for the action of heat on ammonium dichromate(VI).

(ii) What mass of ammonium dichromate(VI) must be completely decomposed in order to obtain 1 g of steam?

(Relative atomic masses: N = 14; H = 1; Cr = 52; O = 16)

(**Answer in grams to 2 sig. fig.**)

Section A - Compulsory Section

A7.

The "half-life" of a radioactive element is the time it takes for a given mass of that element to decay to half its original mass.

The half-life of radon is 3.8 days.

(i) How long would it take for 10 g of radon to decay to 2.5 g of radon?

(Answer in days to 2 sig. fig.)

(ii) Which of the atoms labelled X below are isotopes of radon? **(Tick box for all correct answers)**

${}_{86}^{218}\text{X}$

${}_{87}^{221}\text{X}$

${}_{86}^{222}\text{X}$

${}_{88}^{223}\text{X}$

${}_{87}^{223}\text{X}$

${}_{88}^{226}\text{X}$

A8.

One method of testing for sulphur dioxide in a sample of polluted air is to bubble the air through an acidified solution of potassium dichromate(VI).

The ionic equation for this reaction is given below

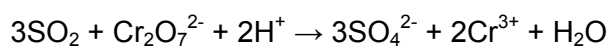

A solution contains 0.1M of dichromate(VI) ions. Calculate the minimum volume of this solution required to remove the sulphur dioxide from 2 dm³ of polluted air which contains 3.6% by volume of sulphur dioxide, measured at r.t.p.

One mole of any ideal gas occupies 24 dm³ at r.t.p. (room temperature and pressure)
(Answer in dm³ to 2 sig. fig.)

Section A - Compulsory Section

A9.

A certain quantity of electricity liberates 9 g of aluminium. The mass of copper liberated from copper(II) sulphate solution (Cu^{2+} ions) by the same quantity of electricity is: (Relative atomic masses: Al = 27; Cu = 64) (**Tick box to mark correct answer**)

- 9.0 g
- 21.33 g
- 32.0 g
- 42.67 g
- 64.0 g

A10.

100 g of water at 15 °C dissolves at saturation 37 g of sodium chloride and 25 g of potassium nitrate but at 70 °C the corresponding weights are 38 g and 140 g per 100 g of water respectively.

100 g of a mixture of the above two salts, in equal proportions by weight, are shaken with 100 g of water at 70 °C, until equilibrium is reached. The solution is filtered hot. The hot filtrate is slowly cooled to 15 °C and again filtered. The final filtrate is evaporated to dryness.

What will be the weights and composites of the three residues, assuming that no solution is left in either of the filter papers? (**Answer in grams to integer number of grams**)

Section B – Bonus Section

Candidates should attempt as many questions in this section as possible

B1.

One of the hydrocarbons in petrol is octane.

This equation shows the combustion of octane:

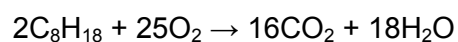

What mass of carbon dioxide is produced for every tonne of octane burned in this reaction?

(Relative atomic masses: H = 1; C = 12; O = 16)

(Answer in tonnes to 2 sig. fig.)

B2.

In an experiment to determine the amount (in moles) of 'water of crystallisation' contained within 1 mole of hydrated zinc sulphate $\text{ZnSO}_4 \cdot x\text{H}_2\text{O}$, a pupil heated some hydrated zinc sulphate crystals until all of the water of crystallisation had been driven out. The following results were obtained:

Mass of empty crucible = 22.87 g

Mass of crucible + crystals = 25.86 g

Mass of crucible + anhydrous salt = 24.55 g

Use this information to calculate the integer x in the formula $\text{ZnSO}_4 \cdot x\text{H}_2\text{O}$

(Relative atomic masses: H = 1; O = 16; S = 32; Zn = 65)

Section B – Bonus Section

B3.

1.0 dm³ of ammonia was passed over heated copper(II) oxide (CuO). The nitrogen formed (measured at the same temperature and pressure as the ammonia) would have a volume of: **(Tick box to mark correct answer)**

- 250 cm³
- 500 cm³
- 750 cm³
- 1000 cm³
- 2000 cm³

B4.

1.44 g of an oxide of copper gave 1.28 g of copper on reduction. What is the formula of the oxide? (Relative atomic masses: Cu = 64, O=16) **(Tick box to mark correct answer)**

- CuO
- Cu₂O
- CuO₂
- Cu₃O
- CuO₃

Section B – Bonus Section

B5.

(i) Calculate the maximum weight of barium sulphate, BaSO_4 , that can be precipitated by 100 cm^3 of 0.05M sulphuric acid. (Relative atomic masses: Ba = 137; S = 32; O = 16) (**Answer in grams to 4 sig. fig.**)

(ii) Calculate the maximum volume of hydrogen, measured at r.t.p., that can be liberated by the action of 100 cm^3 of 0.5M hydrochloric acid on magnesium.
One mole of any ideal gas occupies 24 dm^3 at r.t.p.
(**Answer in dm^3 to 2 sig. fig.**)

B6.

The volume of 8.0 g of oxygen is 7.50 dm^3 under certain conditions. What would be the volume of 8.0 g of methane under the same conditions? (Relative atomic masses: H = 1; C = 12; O = 16) (**Tick box to mark correct answer**)

- 3.75 dm^3
- 7.50 dm^3
- 11.25 dm^3
- 15.00 dm^3
- 18.75 dm^3

Section B – Bonus Section

B7.

The ingredients in lemonade are:

A carbonated water

B sugar

C glucose syrup

D citric acid

E flavourings

F acidity regulator (sodium citrate)

G preservative (sodium benzoate)

H artificial sweetener (Saccharin)

Use the list of ingredients above to help you to answer this question:

Which is the substance in lemonade which

(i) could be fermented into alcohol? (**Write appropriate letter**)

(ii) will turn blue litmus red? (**Write appropriate letter**)

The preservative in this lemonade is sodium benzoate. Its formula can be represented as:

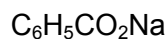

(iii) Name the metal present in the compound.

(iv) State the number of different elements present in the compound.

Section B – Bonus Section

B8.

The action of heat on sodium hydrogencarbonate is represented by the following equation:

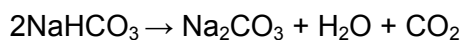

(Relative atomic masses: H = 1; C = 12; O = 16; Na = 23)

- (i) Calculate the mass of one mole of carbon dioxide.
(Answer in grams to 2 sig. fig.)

- (ii) Calculate the mass of one mole of sodium hydrogencarbonate, NaHCO₃.
(Answer in grams to 2 sig. fig.)

- (iii) Calculate the number of moles of sodium hydrogencarbonate in 4.2 g.
(Number to 2 sig. fig.)

- (iv) How many moles of carbon dioxide are formed from 4.2 g of sodium hydrogencarbonate? **(Number to 2 sig. fig.)**

- (v) What mass of carbon dioxide is formed from 4.2 g of sodium hydrogencarbonate? **(Answer in grams to 2 sig. fig.)**

- (vi) What use does the above reaction have in baking? **(in fewer than 15 words)**

- (vii) Sodium hydrogencarbonate is used in the pharmaceutical industry as a component of anti-acid medicines. Explain why it is used in this way **(in fewer than 15 words)**.

Section B – Bonus Section

B9.

Which one of the following compounds does not yield oxygen on moderately strong heating? (**Tick box to mark correct answer**)

- Copper nitrate
- Lead nitrate
- Potassium nitrate
- Iron (III) oxide
- Lead(IV) oxide

B10.

(a) Lead is extracted from the ore galena, PbS, by roasting in air to produce lead(II) oxide, PbO:

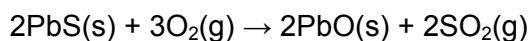

(Relative atomic masses: Pb = 207; S = 32; O = 16)

- (i) Calculate the mass of PbO produced from 2390 g of galena, PbS.
(**Answer in grams to 4 sig. fig.**)

The lead(II) oxide is reduced to lead by heating it in a blast furnace with carbon:

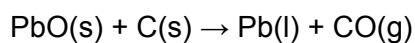

- (ii) Using your previous answer, calculate the mass of lead that would eventually be produced. (**Answer in grams to 4 sig. fig.**)

Section B – Bonus Section

(b) The metal lead forms several oxides. The formula of lead oxide may generally be represented as Pb_xO_y .

To find the formula of a sample of lead oxide, a dish was weighed and the mass recorded. The dish was then filled with the lead oxide and weighed again.

The dish was then placed in a hard-glass tube and heated in a stream of hydrogen gas. The hydrogen reduced all of the lead oxide to a bead of silvery lead metal. The apparatus was allowed to cool and the dish and its contents were reweighed.

Mass of dish = 21.35 g

Mass of dish + lead oxide = 28.20 g

Mass of dish + lead metal = 27.56 g

- (i) Calculate the mass of lead metal produced. (**Answer in grams to 3 sig. fig.**)
- (ii) Calculate the mass of oxygen present in the lead oxide. (**Answer in grams to 3 sig. fig.**)
- (iii) Using your answers to (i) and (ii), calculate the formula of the sample of lead oxide, Pb_xO_y . (Relative atomic masses: Pb = 207; O = 16)

x =

y =

Section B – Bonus Section

B11.

A sample of 50 cm³ of carbon monoxide was burned in 50 cm³ of oxygen. What was the composition of the gas remaining after the reaction? (All measurements were made at the same temperature and pressure) (**Tick box for correct answer**)

- 50 cm³ of carbon dioxide only
- 100 cm³ of carbon dioxide only
- 50 cm³ of carbon dioxide and 25 cm³ carbon monoxide
- 50 cm³ of carbon dioxide and 25 cm³ of excess oxygen
- 75 cm³ of carbon dioxide and 25 cm³ of excess oxygen

B12.

10 dm³ of nitrous oxide (dinitrogen monoxide) are passed over heated copper and the gas formed is collected. If the reaction goes to completion, and all volumes are measured at r.t.p., what is the volume of the gas collected and the mass of the copper(II) oxide formed? (Relative atomic mass Cu = 64)

One mole of any ideal gas occupies 24 dm³ at r.t.p.

(Volume in dm³ to 2 sig. fig., mass in grams to 3 sig. fig.)

B13.

Which one of the following reactions does **not** take place in a blast furnace (**tick the box to mark answer**):

- $C + O_2 \rightarrow CO_2$
- $CO_2 + C \rightarrow 2CO$
- $2Fe + 3CO_2 \rightarrow Fe_2O_3 + 3CO$
- $CaCO_3 \rightarrow CaO + CO_2$
- $CaO + SiO_2 \rightarrow CaSiO_3$

Section B – Bonus Section

B14.

A brass spoon is to be electroplated with silver, as shown in the circuit diagram.

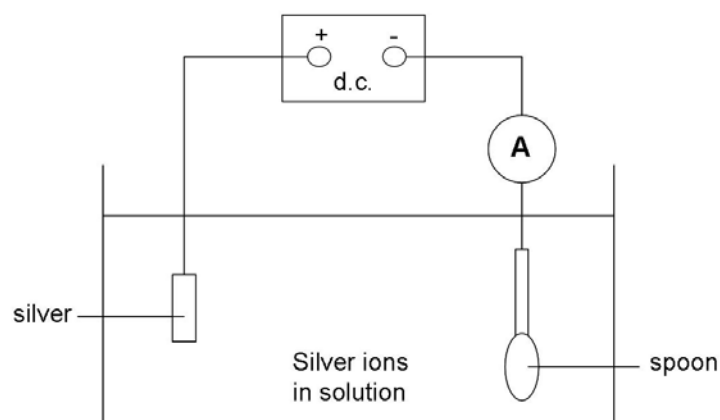

A constant current is used for a duration of 34 minutes.

The spoon increases in mass by 0.46 g due to the silver plating.

The equation for the reaction at the negative electrode is:

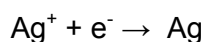

What is the value of current used?

Relative atomic mass: Ag = 108.

96 000 coulombs of electricity (1 faraday) is the charge on a mole of any singly charged entity

1 amp = 1 coulomb per second

(Answer in amps to 2 sig. fig.)

B15.

The isotope $^{14}_6\text{C}$ is radioactive, is a beta emitter and has a half-life of 5730 years.

Which **one** of the following statements about the isotope is true?

(Tick box to mark correct answer)

- It is used to generate electricity in a power station
- In 5730 years, 1 g of the isotope will decay to 0.25 g
- The mass number of the element formed by the radioactive decay is 12
- The radiation emitted will be stopped by a piece of paper
- The atomic number of the element formed by the radioactive decay is 7

Section B – Bonus Section

B16.

A radioisotope that can be found in rock is ^{238}U .

It has an atomic (proton) number of 92 and a mass number of 238.

- (i) Give the number of protons, neutrons and electrons in an atom of ^{238}U

protons:.....

neutrons:

electrons:

- (ii) ^{238}U atoms split up to give a different element. This has an atomic (proton) number of 90 and a mass number of 234.

What is the symbol for this new element?

B17.

The formula of magnesium chloride is MgCl_2 .

Calculate the relative formula mass of magnesium chloride.

(Relative atomic masses: Cl = 35.5; Mg = 24)

(Answer in grams to 2 sig. fig.)

Section B – Bonus Section

B18.

Industry makes use of the following processes:

- A catalysis
- B electrolysis
- C fractional distillation
- D hydrolysis
- E reduction

Choose the process which is outstandingly important in the industrial preparation of **(write the letter next to the lines below)**.

- (i) chlorine
- (ii) iron
- (iii) nitrogen
- (iv) soap
- (v) sulphur trioxide

B19.

A small butane gas lighter contains liquid butane, C₄H₁₀.
Complete the following equation which represents the reaction taking place when 1 mole of butane is burned completely in air: **(balance using whole numbers)**

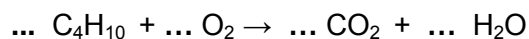

It was found in an experiment that when 0.02 moles of butane was burned, 32 kJ of energy were produced.

Calculate the energy produced when 1 mole of butane is burned.

(Answer in kJ to 4 sig. fig.)

Section B – Bonus Section

B20.

A process called dialysis may be used for patients whose kidneys malfunction; this 'washes' their blood in a kidney machine. The water in the washing fluid has to be highly purified, especially from significant quantities of calcium ions.

The water can be purified by 'ion-exchange'. The water is passed through a resin which exchanges calcium ions for less harmful ones. If the resin is represented by HR , the reaction during 'ion-exchange' can be represented by the following equation:

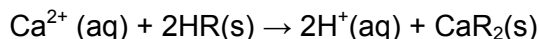

A 10 cm^3 sample of water known to contain Ca^{2+} ions was passed through a resin column. The water was collected and in a titration it was found to neutralise 8.0 cm^3 of 0.001 mol/dm^3 aqueous sodium hydroxide.

(Relative atomic mass Ca = 40)

(i) How many moles of hydroxide ions, OH^- , are neutralised in the titration?
(Answer to 1 sig. fig.)

(ii) How many moles of hydrogen ions are in the 10 cm^3 sample of water?
(Answer to 1 sig. fig.)

(iii) How many hydrogen ions are replaced by each Ca^{2+} ion in the resin?
(Answer to 1 sig. fig.)

(iv) How many moles of Ca^{2+} ions were in the 10 cm^3 sample of water?
(Answer to 1 sig. fig.)

(v) What is the mass of Ca^{2+} ions in 1 dm^3 of the original water?
(Answer in g/dm^3 to 2 sig. fig.)

(vi) Assuming that a dialysis patient needs water containing less than 0.01 g/dm^3 of Ca^{2+} ions, decide whether the sampled water is suitable for use in dialysis.
(Tick the appropriate box)

Suitable

Unsuitable

Section B – Bonus Section

B21

(a) A 10.00 g sample of an alcohol was found, on analysis, to contain 3.75 g of carbon, 1.25 g of hydrogen, and 5.00 g of oxygen. Work out the empirical formula of this alcohol. (Relative atomic masses: C = 12; H = 1; O = 16)
(Write the empirical formula on this answer sheet)

(b) The table shows some bond energies, E.

bond	E/kJ per mole
C - H	413
C - C	347
O - H	464

The dissociation of ethanol is shown below.

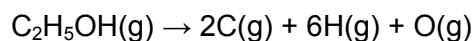

The dissociation energy is 3234 kJ per mole of ethanol.
What is the bond energy of C – O? **(Answer in kJ/mol to 3 sig. fig.)**

Section B – Bonus Section

B22.

(a) A compound **X** contains 34.5% iron and 65.5% chlorine by mass.
What is its empirical formula? (**Tick box to mark correct answer**)
(Relative atomic masses: Cl = 35.5; Fe = 56)

Fe₂Cl₃

FeCl₂

FeCl₃

Fe₃Cl

B23.

From the list of the five metals:

- A calcium
- B copper
- C lead
- D sodium
- E zinc

Choose the metal: (**Write the letter next to the lines below**)

- (i) whose carbonate and hydroxide are both water soluble.
- (ii) whose anhydrous chloride is a common drying agent.
- (iii) which is least electropositive.
- (iv) which lies between aluminium and iron in the reactivity series.
- (v) which forms an oxide that can oxidise concentrated hydrochloric acid to form chlorine.

Section B – Bonus Section

B24.

A compound containing calcium has the following composition by mass:

Ca: 33.3%, S: 26.7% and O: 40.0%

(Relative atomic masses: Ca=40, S=32, O=16)

The simplest formula of this compound is: **(Tick box to mark correct answer)**

- CaSO
- CaSO₃
- CaSO₄
- Ca₂SO₂
- Ca₂SO₄

B25.

An element *E* forms a hydride EH_4 which contains 90.0% by mass of *E*. If the relative atomic mass of hydrogen is 1.0, then the relative atomic mass of *E* is:

(Tick box to mark correct answer)

- 9
- 22.5
- 36
- 86
- 90

Section B – Bonus Section

B27.

(a) Use the following data to calculate the enthalpy change of formation, ΔH_f^\ominus , of the cyclic triene

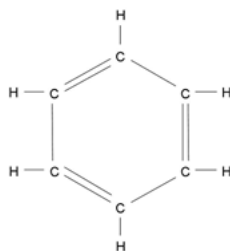

$$\Delta H^\ominus (\text{C}(\text{graphite}) \rightarrow \text{C}(\text{g})) = +716 \text{ kJ/mol}$$

Mean bond enthalpies of dissociation (in kJ/mol):

$$\text{H} - \text{H} : 436 \text{ kJ/mol}, \quad \text{C} - \text{C} : 346 \text{ kJ/mol}, \quad \text{C} = \text{C} : 611 \text{ kJ/mol}, \quad \text{C} - \text{H} : 413 \text{ kJ/mol}$$

(Answer in kJ/mol to 3 sig. fig.)

(b) Calculate ΔH_f^\ominus for benzene using the following data.

$$\Delta H^\ominus (\text{C}_6\text{H}_6(\text{g}) + 3\text{H}_2(\text{g}) \rightarrow \text{C}_6\text{H}_{12}(\text{g})) = -205.2 \text{ kJ/mol}$$

$$\text{And } \Delta H_f^\ominus (\text{C}_6\text{H}_{12}(\text{g})) = -123.1 \text{ kJ/mol}$$

(Answer in kJ/mol to 3 sig. fig.)

Section B – Bonus Section

B28.

Lithium hydride (LiH) reacts with water to give hydrogen and an alkaline solution of lithium hydroxide.

ONLY ON THIS ANSWER SHEET (not on the online exam) write the balanced equation, including state symbols for this reaction.

2.0 g of lithium hydride were treated with an excess of water. Calculate:

(i) the volume at r.t.p. of the hydrogen formed.

(Relative atomic masses: Li = 7; H = 1; O = 16) (**Answer in dm^3 to 2 sig. fig.**)

(ii) the volume of hydrochloric acid containing 73 g of HCl per dm^3 required to neutralise the resulting solution.

(Relative atomic masses: H = 1; Cl = 35.5) (**Answer in dm^3 to 3 sig. fig.**)

Section B – Bonus Section

B29.

Considering the laws of combining volumes, 200 cm^3 of a gaseous element X_2 reacted with 650 cm^3 of a gaseous element Y_2 to form 450 cm^3 of a mixture of XY_3 and Y_2 . It was later found that 50 cm^3 excess of Y_2 remained unused. All volumes were measured under the same conditions of temperature and pressure.

What volume of XY_3 was formed in the reaction? (**Answer in cm^3 to 3 sig. fig.**)

B30.

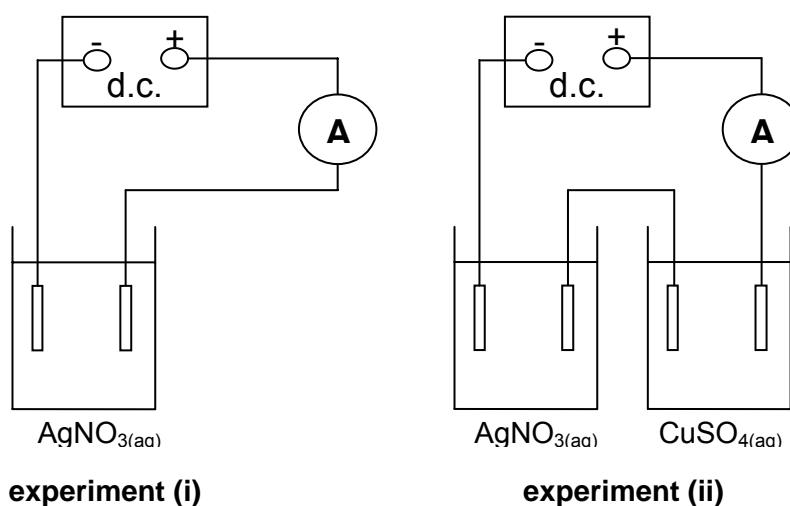

The circuits of two electrolysis experiments, (i) and (ii), are shown in the diagram. The electrodes were platinum and the ammeter reading was 0.5 A in both experiments.

In experiment (i), 1.0 g of silver was deposited in 30 minutes. How long would be needed to deposit 1.0 g of silver in experiment (ii)? (**Tick box to mark correct answer**)

- 20 min 30 min 45 min 60 min 90 min